

## LOW COST WIRELESS ARCHITECTURE FOR RURAL NETWORK CONNECTIVITY USING IOT

**Yogesh Kushwaha**

Assistant Professor

Department of IT

SRM University NCR Campus

Modinagar

**Shailja Singh, Pragati Saxena, Manisha Singh**

B.Tech student

Department of IT

SRM University NCR Campus

Modinagar

**ABSTRACT:** This project work investigates the potential of 'Remote Appliance Control', which is the aim of our project for the development of connectivity of rural areas in near future. The analysis and implementation of the remote control automation using Global System for Mobile Communication (GSM) modem to control home appliances such as light, conditional system, and security system via Android app which is presented in this project. The proposed research work is focused on functionality of the GSM protocol, which allows the user to control the target system away from residential using the frequency bandwidths. The concept of serial communication and AT-commands has been applied towards development of the smart GSM-based remote appliance control system. Rural area people will be able to receive feedback status of any home appliances under control whether switched on or off remotely from their mobile phones. PIC16F876a microcontroller with the integration of GSM provides the smart automated appliance system with the auto baud rate. Basic aim of this project is to deliver low cost efficient rural wireless network using IOT which we are delivering via app and GSM sim.

IOT means inter-networking of physical devices or smart devices embedded with electronics, software, sensors, actuators, and network connectivity that enable these objects to collect and exchange data. IOT allows objects to be sensed or controlled remotely across existing network infrastructure. Which results in improved efficiency, accuracy and economic benefit in addition to reduced human intervention?

**KEYWORDS:** IOT, GPRS, Remote Control System, Rural Area Network, Application, SMS, Wireless Architecture, Cost effective.

### I. INTRODUCTION

Many rural regions around the world, especially in developing regions, do not have good connectivity solutions which are economically viable. As a result, many of these regions remain disconnected from both the rest of the world and from progress in general.

In this proposal, We will describe the design of GSM based Rural Extensions, a wireless network architecture that can provide connectivity to rural regions at extremely low costs.

None of the traditional wire-line connectivity solutions (fiber, broadband and dial-up) are economically viable for such regions over at least the next decade due to low user densities. Satellite networks provide great rural coverage.

### II. MOTIVATION

Rural areas have been away from normal pace of development since long, but today every rural area is being covered under the normal networking providing facilities like calling and 2G internet. With this idea in mind we thought about providing them comfort with these concepts and facilities in mind. So we decided to provide services like remote control of devices using IOT

It shouldn't be a surprise that industrial occupations will benefit greatly from IOT integration. Dangerous situations are the norm for factories and plants, where workers live and die by monitoring highly stressed machines. Really, coal miners were the first to embrace IOT by using canaries as sensors to tell when an area became unsafe, jokes VP and global innovation evangelist at SAP Timo Elliott. The black humor belies the high stakes of industrial work, where inattention could maim or kill.

### III. METHODOLOGY

- GSM hardware tests are run in order to check the hardware support. The system will call GSM modem and it will get activated.
- After activation the Modem will check for hardware support. If the hardware is missing or some other hardware problem there will be error, resulting in communication failure and the application will be terminated.
- If hardware responds then the serial port will be opened for communication and GSM hardware will allow transmission of data from application and SMS.
- The system will then connect and after connection establishment the data will transmit allowing control of the devices and may also represent data related to it.

### IV. LITERATURE REVIEW

In this literature survey two broad areas have been taken into consideration: first is how much research has already been directly on the subject IOT that analyses wireless communication.

Secondly how much work has been done in the field of force directed approach with respect to IOT? The following is an account of literature survey that I conducted while researching on this subject & making the project.

IOT is redefining connectivity in two ways that directly benefit the end user:

- 1) Users connecting to smart devices to accomplish a task.
- 2) Smart devices connecting with ordinary objects to deliver additional information, functionality, or value.

In many factories and plants, the only place with a complete picture of what's happening everywhere is in the control room where all the information feeds in. Thus, whoever's in the control room is the only one with the knowledge to take action. But by feeding that information into the cloud, anyone with a smart device can see that information all over the factory—and by running analytics on that data up in the cloud in real time, trends and conclusions can be sent to those smart devices as well. That information isn't limited to technicians zooming around the factory floor: Offsite managers and supervisors can monitor progress and remote experts can be consulted. "There will be new jobs, new tasks, and new skills required in order to achieve the next levels of economic activity in an IOT world."

### V. SYSTEM OVERVIEW

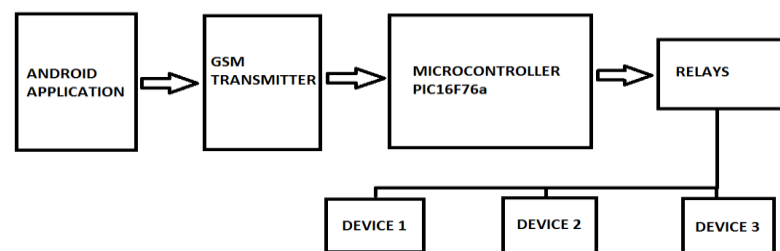

Fig. System Overview

The system has an android application with some basic features. It will have GSM Transmitter which will transmit the information on the server and exchange data through it using database. This information thus requested and taken will change the bits of the data and hence ask microcontroller to change the present value of the requested device.

### VI. IOT

The Internet of Things (IOT) is a system of interrelated computing devices, mechanical and digital machines, objects, animals or people that are provided with unique identifiers and the ability to transfer data over a network without requiring human-to-human or human-to-computer interaction.

A thing, in the Internet of Things, can be a person with a heart monitor implant, a farm animal with a biochip transponder, an automobile that has built-in sensors to alert the driver when tire pressure is low -- or any other natural or man-made object that can be assigned an IP address and provided with the ability to transfer data over a network.

Practical applications of IOT technology can be found in many industries today, including precision agriculture, building management, healthcare, energy and transportation.

### VII. WIRELESS COMMUNICATION

Wireless communication is among technology’s biggest contributions to mankind. Wireless communication involves the transmission of information over a distance without help of wires, cables or any other forms of electrical conductors. The transmitted distance can be anywhere between a few meters (for example, a television’s remote control) and thousands of kilometers (for example, radio communication).

### VIII. CIRCUIT DIAGRAM

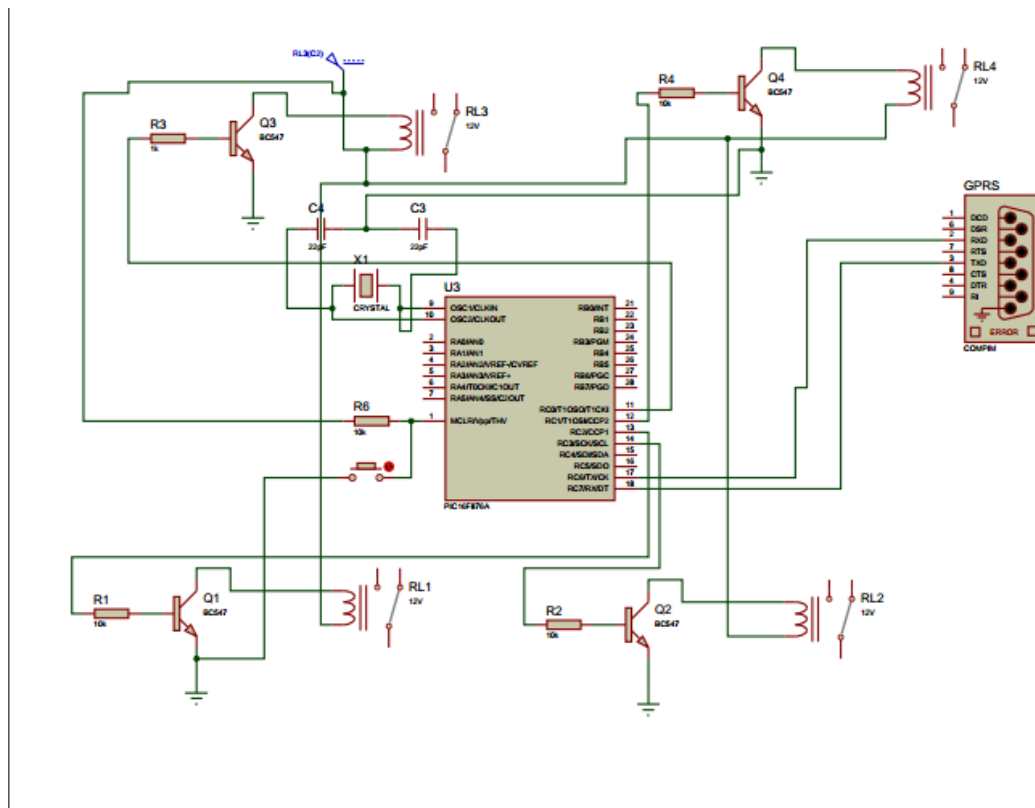

## IX. MICROCONTROLLER

Powerful (200 nanosecond instruction execution) yet easy-to-program (only 35 single word instructions) CMOS FLASH-based 8-bit microcontroller packs Microchip's powerful PIC® architecture into an 28-pin package and is upwards compatible with the PIC16C5X, PIC12CXXX and PIC16C7X devices. The PIC16F876A features 256 bytes of EEPROM data memory, self programming, an ICD, 2 Comparators, 5 channels of 10-bit Analog-to-Digital (A/D) converter, 2 capture/compare/PWM functions, the synchronous serial port can be configured as either 3-wire Serial Peripheral Interface (SPI™) or the 2-wire Inter-Integrated Circuit (I<sup>2</sup>C™) bus and a Universal Asynchronous Receiver Transmitter (USART).

## X. GPRS

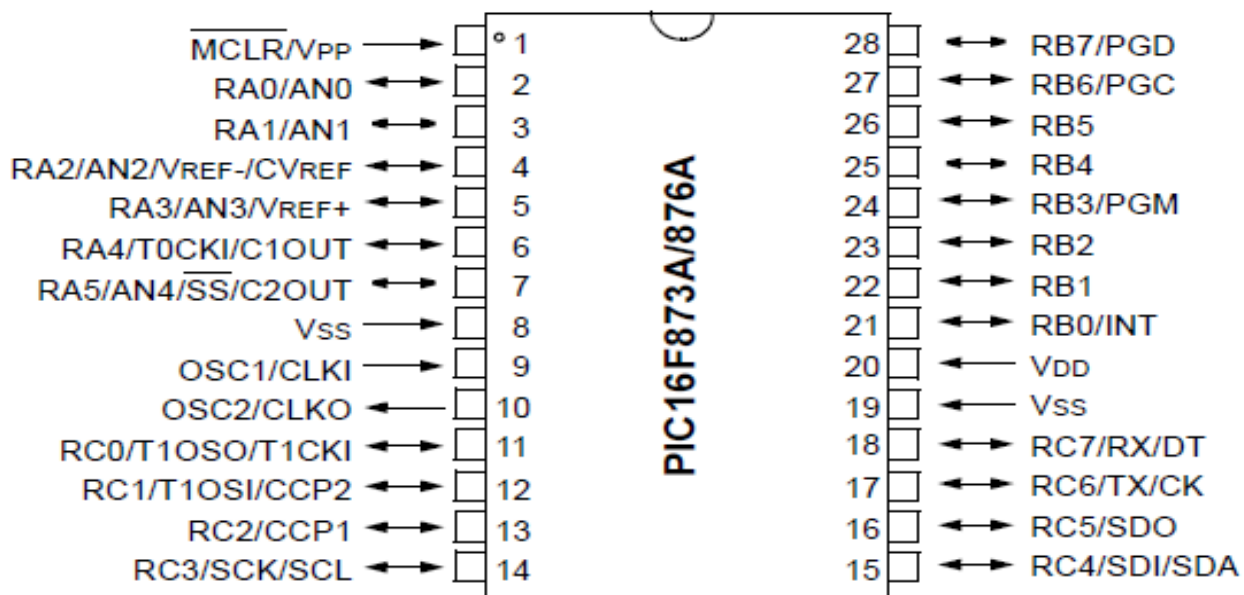

Is a general packet radio service is a packet-based mobile data service on the global system for mobile communication (GSM) of 2G and 3G cellular communication system.

GPRS is based on wireless communication service that promises data rates from 56 up to 114kbps and continous connection to the internet for mobile and computer (PC), and it is non-voice and high-speed technology.

## XI. GSM MODULE

Is a global system for mobile communication is a standard developed by European telecommunication standards Institute (ETSI) to describe the protocol for (2G) digital cellular network used by mobile phone.

GSM uses a variation of time division multiple access (TDMA) and is the most widely used of the three digital wireless telephony technologies (TDMA, GSM, CDMA).



### XII. APP ALGORITHM

Application will be coded using MIT App Inventor. For the basic application we will have 3 buttons for each device and each device button will provide the option of turn on and off the device by touching it. We can further add features to the app accordingly.

And there will be 3 PHP pages-

1. To create table in database.
2. To insert values in table.
3. To request value from table.

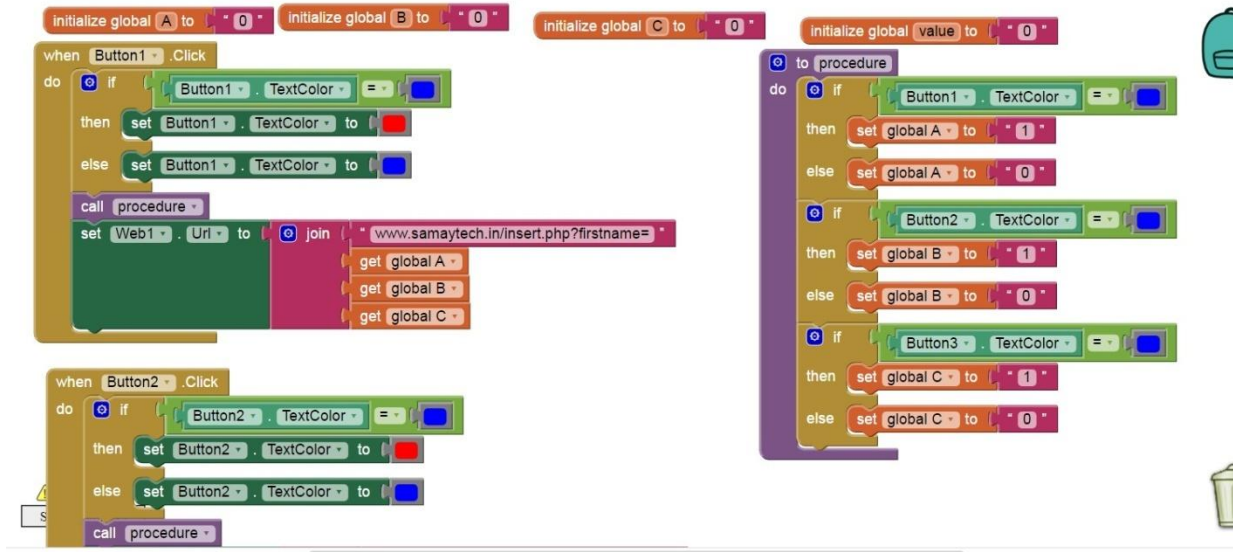

### XIII. RESULT

The project revolves around the concept of INTERNET OF THINGS implementation. When the person requests the microcontroller for changing the state of the device using internet then the server tells the present state of the device and offer to change it. This changing is done by an app which is the user interface and provides encapsulation to all the processes running behind. Also providing the same service using SMS. The application will run and send the data to the through php to microcontroller which in return will send it further through internet to the database server and ask for change of state. Once the state is changed in the database the request is answered and microcontroller in return changes the state of the device requested.

#### XIV. CONCLUSION

From the research and analysis of our project entitled as ‘Low Cost Wireless Architecture For Rural Network Connectivity’, it has proved to be inexpensive, easy to use and don’t wear out. In this project wireless communication based on IOT is proposed. Despite some delays in the operation of the appliances, it was observed that the proposed system can save electricity, man-power and tension.

Following are the advantages of this project:

- I. Communication has enhanced to convey the information quickly to the consumers.
- II. Working professionals can work and access Internet anywhere and anytime without carrying cables or wires wherever they go. This also helps to complete the work anywhere on time and improves the productivity.
- III. Doctors, workers and other professionals working in remote areas can be in touch with medical centres through wireless communication.
- IV. Urgent situation can be alerted through wireless communication. The affected regions can be provided help and support with the help of these alerts through wireless communication.
- V. Wireless networks are cheaper to install and maintain.

#### XV. REFERENCES

1. Mr. Y.N. Prajapati, Department of IT faculty, SRM University regarding the hardware and electronics work.
2. James Gerhart “Home Automation and Wiring” book complete construction Dodge cost guides ++ series McGraw-Hill's complete construction series
3. Pasupuleti Ramanatha; Usha Rani Nelakuditi; S. Ravishankar; V. Ranganathan2016 “ UAV based smoke plume detection system controlled via the short message service through the GSM network” International Conference on Inventive Computation Technologies (ICICT)Year: 2016, Volume: 2
4. “Analysis and Performance of a Low Cost SMS Based Home Security System”, Sheikh Izzal Azid, Sushil Kumar, International Journal of Smart Home, vol. 5, no. 3, (2011) July